



Key Lock



Latch Lock Drawers



Ball Bearing Slides

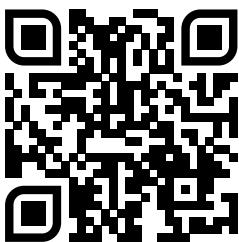

Edition : 1.0
Date: (05/26)

Instruction Manual

PROFESSIONAL SERIES SIDE CABINET TPS-65D

Order Code: (T6888)

SIDE CABINET



PROFESSIONAL SERIES

BEFORE ASSEMBLING

Please read this instruction manual before assembly.



CAUTION

Before assembly please pay attention to the following points in priority;

Confirmation of components: Before assembling, please confirm all parts arrived and are in good order.

Site for assembly: Please assemble it on the soft floor such as smooth carpet and flannel blanket. When you assemble on wooden floor, please put thin towels on the floor.

Points for attention when assembling: Please wear gloves to ensure that it can be assembled safely, and use two persons to help in the assembly process.

SAFETY INFORMATION

1. This product should only be assembled, repaired or modified by qualified persons.
2. Keep children, infants and pregnant women away from the installation and assembly area.
3. Use two persons or suitable lifting equipment to attach the side cabinet to the roller cabinet. Carefully lower the rolled steel lip onto the side of the roller cabinet, then secure using the two supplied bolts through the tapped holes located at the bottom of the roller cabinet.
4. Do not attempt to lift or move the cabinet while drawers are loaded.
5. Do not overload the drawers. Ensure all drawers are fully closed and locked before moving the cabinet.
6. Do not open more than one drawer at a time. Distribute tools and contents evenly between drawers to maintain stability.
7. Do not perform welding, hammering or disassembly work on the top surface of the cabinet.



CAUTION: Do not stand on this product. You may fall which may cause personal injury or product damage.



CAUTION: Keep the product on level surfaces. The product may become unstable and tip if stored or moved on an un-level surface, which may cause personal injury or product damage.



CAUTION: Be careful when opening more than one drawer. The product may become unstable and tip, which may cause personal injury or product damage.



CAUTION: Lock the drawers before moving this product. The drawers could come open and make the product unstable and tip, which may cause personal or product damage.



CAUTION: Only fit side cabinet to a matching roller cabinet. Locate the rolled steel lip onto the cabinet and secure using the two supplied bolts before use.



CAUTION: Do not lift while loaded. Have assistant help place on roller cabinet while using the correct mechanical lifting aids.



SIDE CABINET



PROFESSIONAL SERIES

SPECIFICATIONS

Overall size: 370 x 559 x 900mm (WxDxH)

Package size: 580 x 640 x 980mm (WxDxH)

1st Drawer: 270 x 500 x 140mm (50kg)

2nd Drawer: 270 x 500 x 75mm (50kg)

3rd Drawer: 270 x 500 x 75mm (50kg)

4th Drawer: 270 x 500 x 115mm (50kg)

5th Drawer: 270 x 500 x 155mm (100kg)

6th Drawer: 270 x 500 x 179mm (100kg)

Nett Weight: 50kg



Keys (x4)



Full-Width
Drawer Opening
Latches (x6)

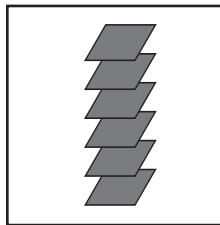

Foam Liners (x6)

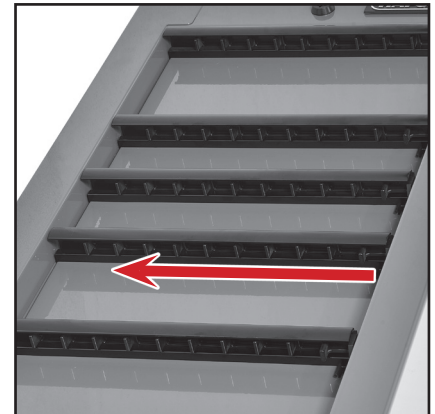

Slide drawer latch to left to open

DRAWER OPERATION

DRAWER LATCHES - Each drawer is fitted a full-width drawer opening latch. SLIDE TO LEFT TO OPEN

KEY LOCK - When all drawers are closed. Use the Key to lock all drawers in the cabinet.

SIDE CABINET



PROFESSIONAL SERIES

UNPACKING INSTRUCTIONS

1. **Unbox the Side Cabinet:**

Use a knife to carefully open the carton and remove the cabinet. Be cautious to avoid damaging the contents.

2. **Unlock and Prepare:**

Using the keys provided, unlock the cabinet. Align the foam liners inside each drawer and top rubber matt to ensure they are properly positioned.

3. **Lifting and Positioning:**

The side cabinet weighs 50kg, so it is important to use proper lifting techniques. Ensure you have assistance or appropriate lifting equipment to move it into its final position.



*Tools not included

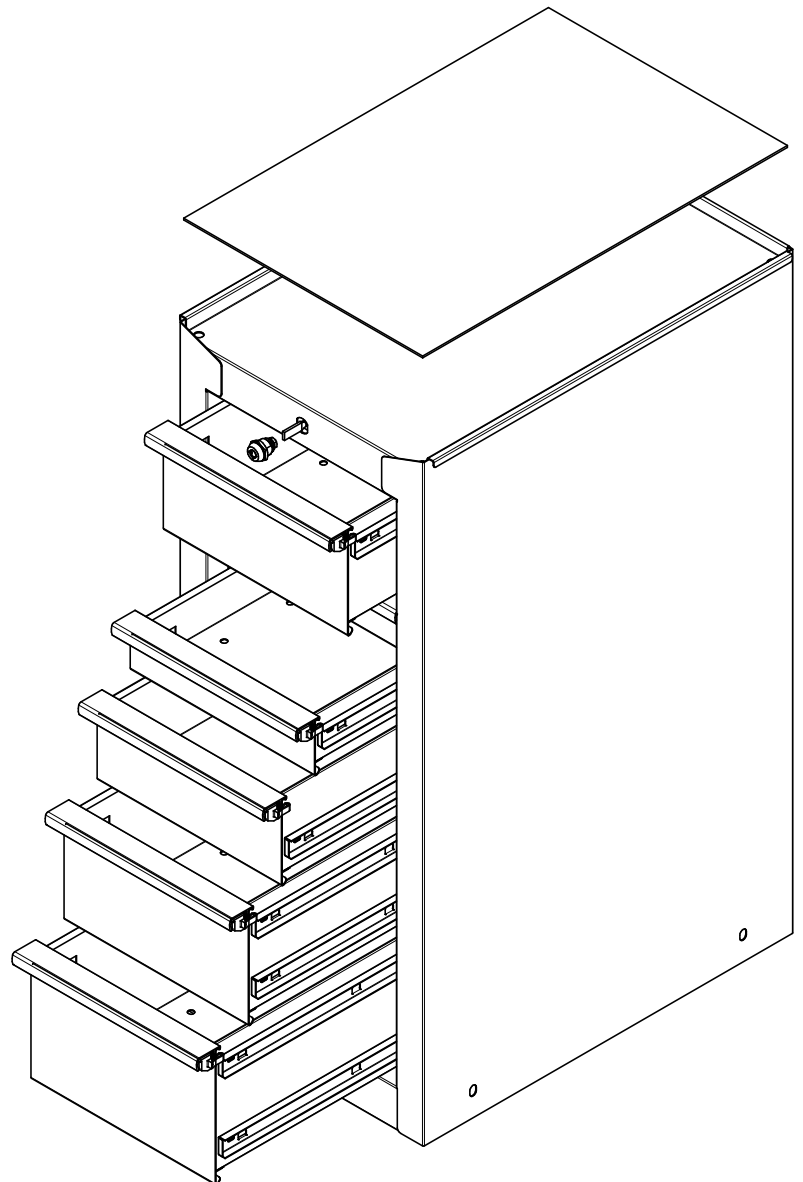

SIDE CABINET

PROFESSIONAL SERIES

REMOVING DRAWERS

1.

Removing the drawers

- Unlock the safety latch and fully extend the empty drawer.
- Push up the one release lever while pulling down on the other release lever.
- Pull the drawer outward until it is released from the drawer slide.

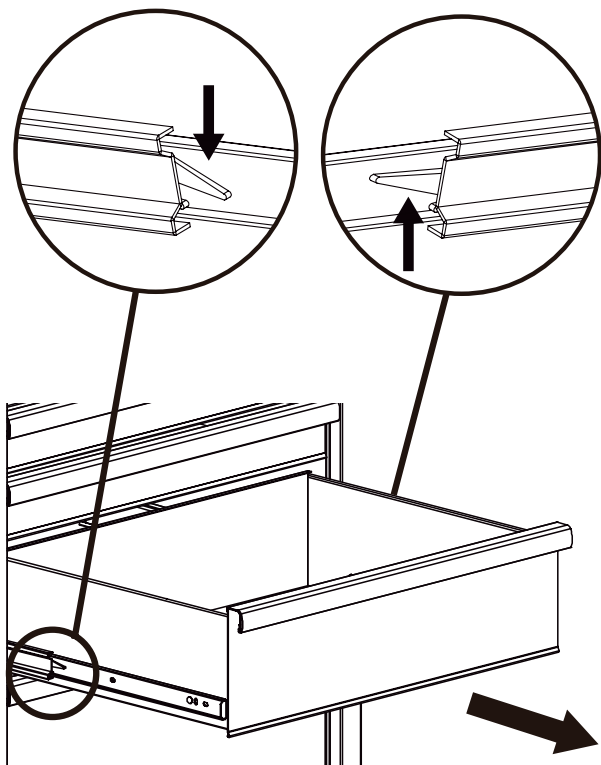

2.

Re-inserting the drawers

- Extend the drawer slides.
- Insert the brackets on each side of the drawer into the slots in the slides, being careful that they are properly positioned.
- Once properly inserted, completely close the drawer to set the slides in their proper positions and make sure you go all the way in to engage the safety lock system.

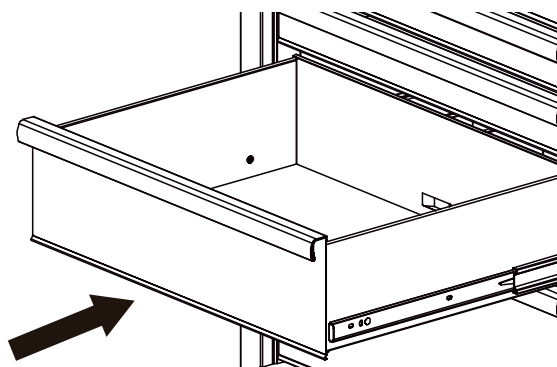

MAINTENANCE

Drawer maintenance: Lubricate the slides semi-annually with high-quality bearing grease.

MOUNTING SIDE CABINET ONTO ROLLER CABINET

1. Close & Lock Drawers

- Ensure all side cabinet and roller cabinet drawers are fully closed.
- Using the supplied key, lock both cabinets before installation. (Fig. 1)



2. Secure the Roller Cabinet

- Position the roller cabinet on a level surface.
- Lock both brake wheels to prevent movement during installation. (Fig. 2)

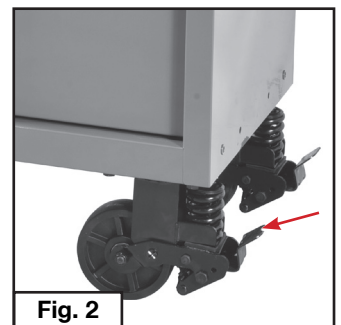

3. Lift Side Cabinet into Position

- Using two persons or suitable lifting equipment, carefully lift the side cabinet onto the preferred side of the roller cabinet.
- Hook the folded steel lip of the side cabinet over the top edge of the roller cabinet. (Fig. 3)

4. Secure with Supplied Bolts

- Install the two supplied bolts through the lower mounting holes into the side of the roller cabinet. (Fig. 4)
- Tighten bolts securely.

5. Ready for use

- Unlock all drawers before use.

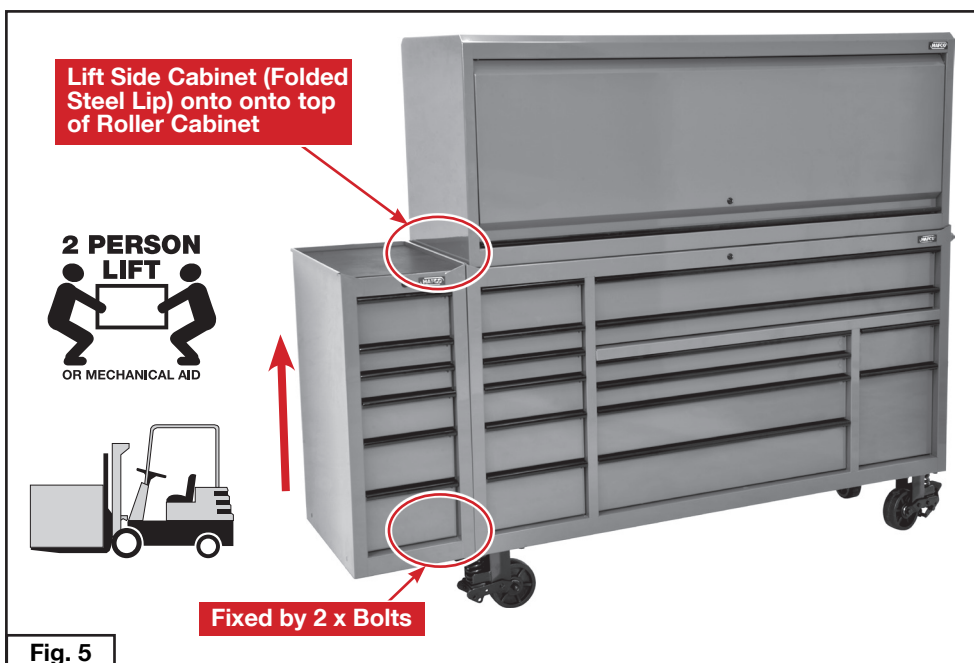
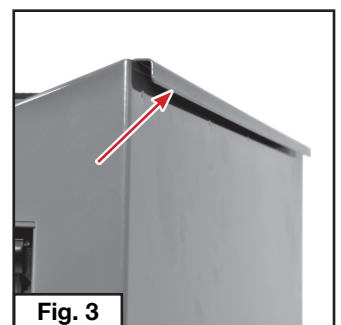



ENVIRONMENT PROTECTION

Recycle unwanted materials instead of disposing of them as waste. All tools, accessories and packaging should be sorted, taken to a recycling centre and disposed of in a manner which is compatible with the environment. When the product becomes completely unserviceable and requires disposal, drain any fluids (if applicable) into approved containers and dispose of the product and fluids according to local regulations.

Imported by

HARE & FORBES
MACHINERYHOUSE

Australian Distributor

Hare & Forbes
Machineryhouse
Sydney - Melbourne
Adelaide - Brisbane - Perth

Ph: 1300 202 200
www.machineryhouse.com.au

MACHINERYHOUSE

New Zealand Distributor

Machineryhouse
Auckland
Christchurch

Ph: 0800 142 326
www.machineryhouse.co.nz